



Egress Windows

Building Inspections | City of Eden Prairie | 8080 Mitchell Road | Office: 952-949-8342

This handout is intended only as a guide and is based in part on the 2020 Minnesota State Building Code, Eden Prairie City ordinances and good building practices. While every attempt has been made to ensure the correctness of this handout, no guarantees are made to its accuracy or completeness. Responsibility for compliance with applicable codes and ordinances falls on the owner or contractor. For specific questions regarding code requirements, refer to the applicable codes or contact the Building Inspections Division.



WHAT IS AN EMERGENCY ESCAPE AND RESCUE OPENING?

- An emergency escape and rescue opening are a window (sometimes called an egress window) or door that is required in specific locations in new or altered dwellings and is intended to provide an emergency means of exiting a dwelling or provide an access for rescue. These openings must meet specific size requirements.

WHERE ARE EMERGENCY ESCAPE AND RESCUE OPENINGS REQUIRED?

- Emergency escape and rescue openings are required in any room used for sleeping purposes (bedrooms) and in basements. If you are constructing a new home, the code requires that you put an emergency escape and rescue opening in each bedroom. It also requires one in the basement.
- In existing homes, you must provide an emergency escape and rescue opening if you create a new bedroom or expand an existing bedroom or your basement. If you have a bedroom in the basement, the emergency escape and rescue opening in that bedroom suffices for the basement. You do not need to provide another opening just for the basement.

WHAT ARE THE SIZE REQUIREMENTS FOR WINDOWS USED AS EMERGENCY ESCAPE AND RESCUE OPENINGS?

A window used as an emergency escape and rescue opening must satisfy four Minnesota Residential Code criteria:

- Minimum width of opening: 20 inches
- Minimum height of opening: 24 inches
- Minimum net clear opening: 5.7 square feet (5.0 square feet for ground floor)
- Maximum sill height above floor: 44 inches

The window must have a minimum net clear opening of 5.7 square feet. Net clear opening refers to the actual free and clear space that exists when the window is open. It is not the rough opening size or the glass panel size, but the actual opening a person can crawl through.

The window opening must be operational from the inside without keys or tools. Bars, grilles and grates may be installed over windows but must be operational without tools or keys and still allow the minimum clear opening.

DO THE MATH

At first glance, you might assume that a 20 by 24-inch window would be acceptable for emergency escape or rescue. However, those dimensions would yield a net clear opening of only 3.3 square feet. To achieve the required net clear opening of 5.7 square feet, a 20-inch wide window would have to be 42 inches high. Likewise, a 24-inch high window would have to be 34 inches wide.

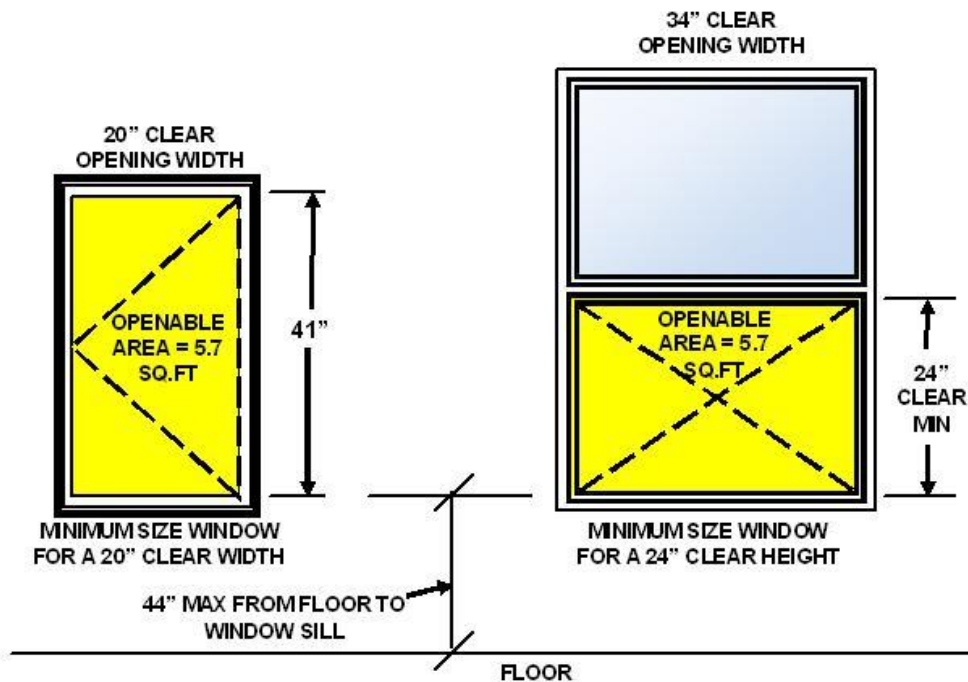

Because Minnesota uses a national model residential code, nearly all window manufacturers specify which of their windows meet these standards. This should take the guesswork out of selecting a window for your addition or remodeling project. Also, the salesperson who sells you the window should be able to help you select a code compliant window if they know you need a window that is required to be an emergency escape or rescue opening.

MUST I USE A SPECIAL TYPE OF WINDOW?

A wide variety of window designs can be used for emergency escape or rescue openings. You should select a window design that meets your architectural, aesthetic, space and financial limitations.

Casement windows with hinged sashes that swing free and clear of the opening can be relatively small and still meet code requirements. This makes them ideal for basements and other areas where space is limited. Some manufacturers can install a special operator arm that allows the window to open wider than the standard operating arm to meet opening requirements. Others have an operator arm that can be pushed to open the window wider in an emergency. These meet egress requirements if you leave the "PUSH HERE" label in place.

Glider or slider windows have sashes that fill nearly half the possible window opening when the window is opened. They require a window nearly twice the size of a casement window.

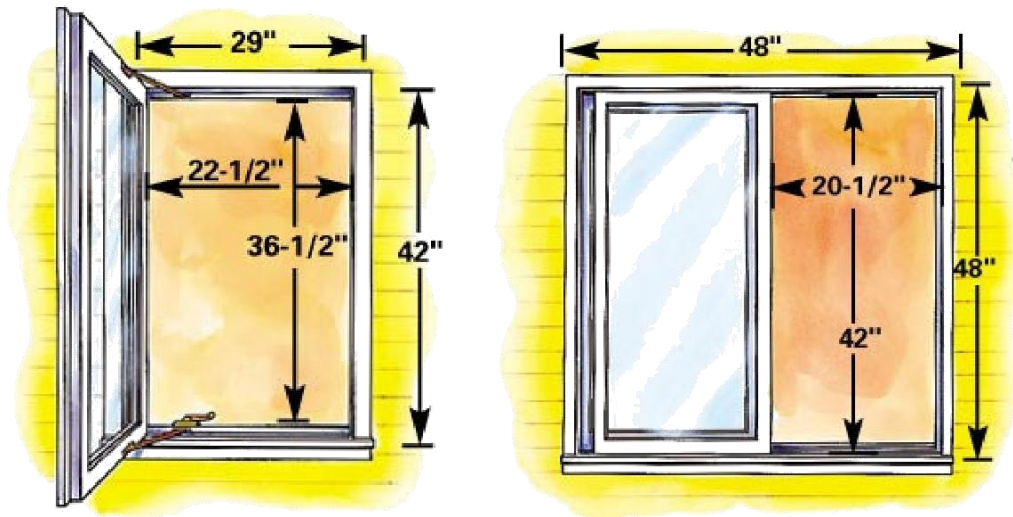

Note: Dimensions shown only for illustration purposes

Even when it is fully open, more than half of a **double-hung window's** overall area is blocked by glass. To meet height requirements, a window must be nearly 4 feet 9 inches in overall height. This height requirement makes it undesirable for most basement situations.

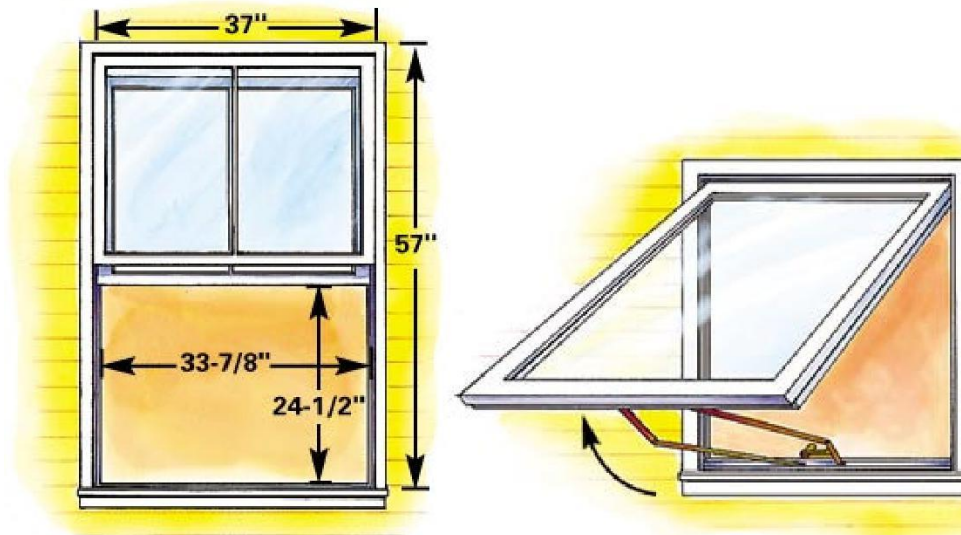

Note: Dimensions shown only for illustration purposes

Awning windows are problematic. Since the opened sash prevents escape from most window wells, they're unsuitable for basement use. And with most awning windows, the center opening hardware and height don't meet opening requirements.

WHY DON'T MY WINDOWS MEET EGRESS REQUIREMENTS?

Some older homes were built before there were emergency escape and rescue opening requirements. Changing rules are responsible for other discrepancies. And sometimes homeowners or contractors engage in work without permits that will result in noncompliance.

BASEMENT WINDOWS USED FOR EMERGENCY ESCAPE OR RESCUE OPENINGS

Because of their location below grade, basement windows present an added challenge. Below-grade windows must have a window well that permits the window to function as an emergency escape or rescue opening. Window wells must:

- Allow the rescue window opening to be fully opened.
- Provide 9 square feet of "floor area," with a minimum dimension of 36 inches in width and length.
- **If the window well depth exceeds 44 inches**, the well must contain a permanently affixed ladder or steps. The ladder must be at least 12 inches wide and project no less than 3 inches from the window well wall. Ladders may not obstruct the operation of the window or project more than 6 inches into the required window well dimensions.

Window wells may be made of rust resistant metal, treated wood, wood naturally resistant to decay, concrete, masonry or plastic. Some window well designs have steps built or molded into them.

If an egress window is located under a deck or porch, the code requires at least 36 inches between the top of the window well and the bottom of the deck or porch joist.

